

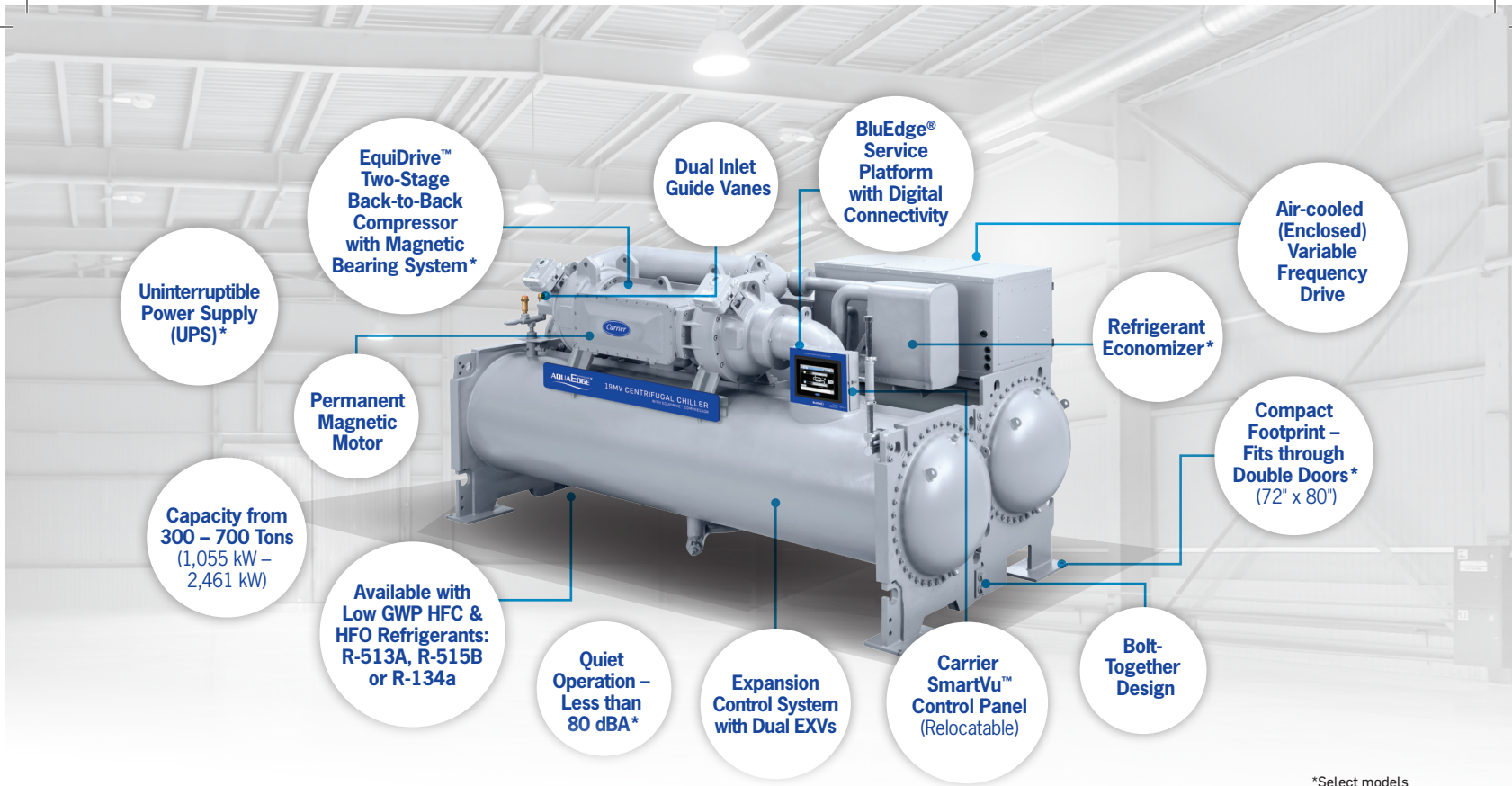

# AQUAEDGE<sup>®</sup> 19MV CENTRIFUGAL CHILLER

Experience Unconditional Performance



## Introducing the all-new AquaEdge 19MV Centrifugal Chiller – designed to deliver high performance and reliability across a wide operating range.

It's time to rethink what you know about chillers. In the past, more operating range often meant less efficiency at design conditions. Now Carrier has created a chiller that delivers both, unconditionally. The all-new AquaEdge 19MV chiller combines best-in-segment efficiency at design and off-design conditions with the ability to operate reliably, even at severe conditions and heavy cooling loads. In other words, Carrier has created a chiller with performance you can count on – no matter what.

We started by building on a proven, game-changing compressor technology – the EquiDrive two-stage back-to-back compressor – for consistent operation across a wider operating envelope. Then we incorporated magnetic bearings and loads of additional options, integrated innovative Carrier SmartVu controls and packaged it all in a quiet, compact design that fits easily through standard double doors.

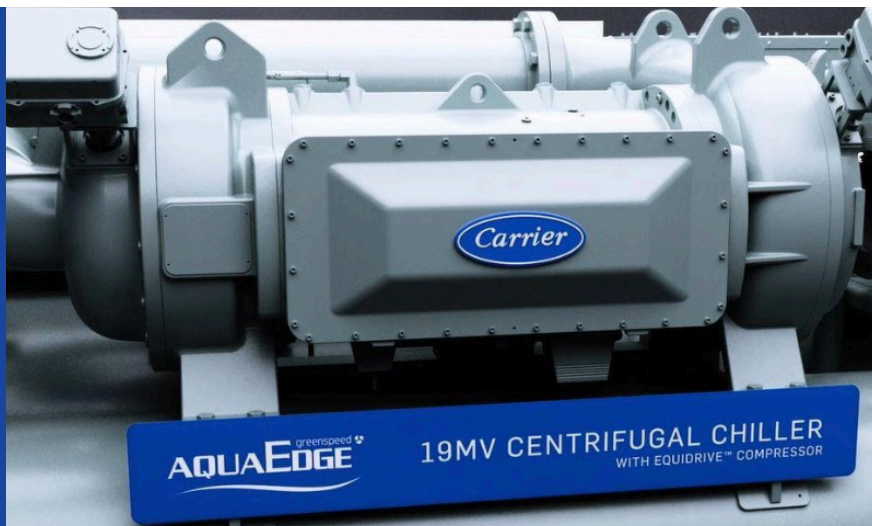

- Reliable performance
- Incredible efficiency
- Flexible options
- Easy installation and control

With the AquaEdge 19MV, you can have it all – unconditionally.

## Unconditional performance starts with an unbeatable compressor.

The AquaEdge 19MV leverages proven EquiDrive two-stage back-to-back compressor technology to achieve best-in-segment performance while staying quiet and cool under pressure.

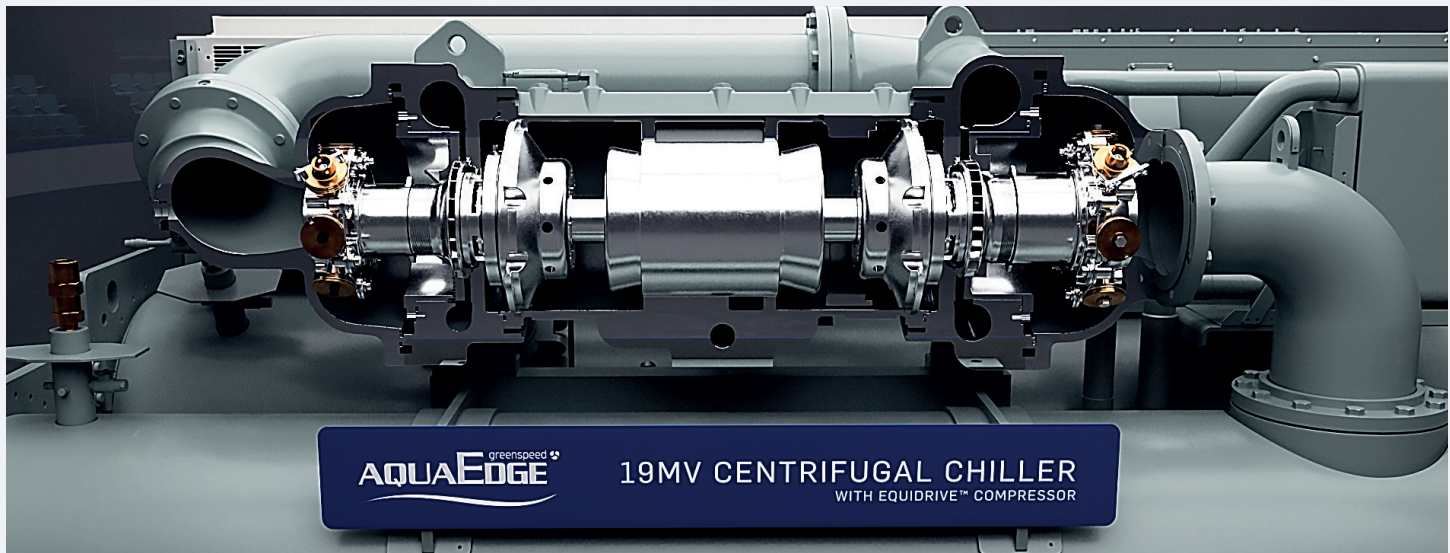

Carrier's revolutionary EquiDrive compression and drive train technology provides More Operating Range while maintaining best-in-segment efficiency at design conditions (MORe). This provides an improvement in both chiller energy efficiency and building resiliency.

Energy is reduced due to better efficiency at common metrics such as full load, 75% load (the "lifecycle point") and Integrated Part Load Value (IPLV). Due to a wider operating range, including the ability to operate at virtually no lift, the AquaEdge 19MV can take full advantage of cold condenser water, chilled water reset and other energy-saving practices to further improve building performance.

In addition, building resiliency is significantly improved with its ability to operate with elevated condenser water temperatures at low and full load. This extended operating range (meaning it may go beyond the typical operating range) is a game-changing capability that provides building owners and facility managers confidence in reliable, efficient operation beyond specifications.

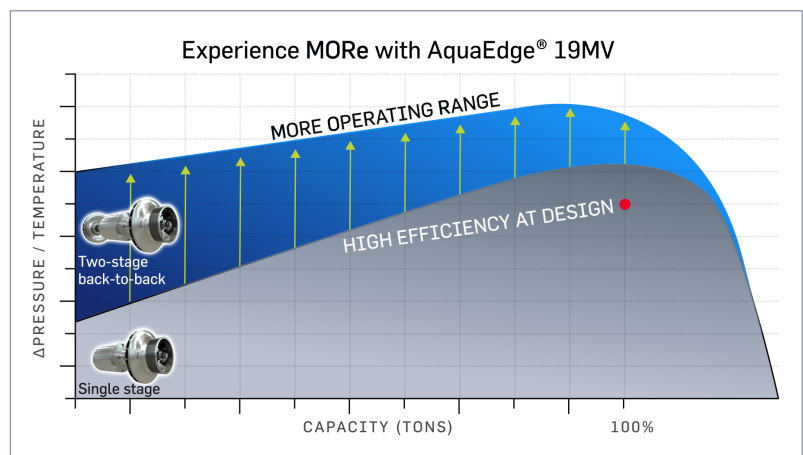

- Achieves <math><0.52\text{ kW/Ton}</math> (6.8 COP) and <math><0.31\text{ kW/Ton}</math> (11.3 COP) (IPLV) at AHRI conditions
- Operating range of 40°F to 95°F (4.4°C to 35°C) entering condenser water down to 10% load
- Expansion control system with dual Electronic Expansion Valves (EXVs) for optimized integrated Waterside Economizer (WSE) operation
- Oil-free magnetic bearing system option available

- Permanent magnet motor improves efficiency at full and part loads
- A more balanced design means reduced thrust loads
- Direct drive simplifies the design
- Streamlined gas flow reduces internal losses
- Optimized dual inlet guide vanes for better efficiency and stability

## Features, options and footprint – all for unconditional flexibility and efficiency.

At Carrier, we made the AquaEdge 19MV with tons of features, options and flexibility so you can implement a solution that meets your specific needs. Explore the features that make this chiller a perfect fit for any building – and almost any cooling need.



### COMPACT FOOTPRINT FOR EASY INSTALLATION

Select models fit through double doors (72" x 80") with no disassembly required. (Bolt-together construction allows for easy disassembly and reassembly if required.)



### REFRIGERANT OPTIONS

Available with your choice of low GWP R-513A, R-515B or R-134a refrigerant.



### QUIET OPERATION

Operates at less than 80 dBA.\*



### EXPANSION CONTROL SYSTEM

Expansion control system (metering device) includes dual EXVs, ensuring full capacity at virtually no lift\* for excellent cold weather performance and providing redundancy at typical operating conditions.



### ECONOMIZER\*

Compact brazed plate economizer leverages the two-stage compressor design to increase refrigerant liquid subcooling and evaporator capacity, ensuring more performance per square foot.



### CONDENSER AND EVAPORATOR

High-performance tubing, low waterside pressure drop and integral subcooling provide high efficiency.



### GREENSPEED® INTELLIGENCE VARIABLE FREQUENCY DRIVE

An air-cooled Variable Frequency Drive (VFD) enables starting and operating with cold condenser water while variable speed operation provides enhanced performance at off-design conditions. The VFD enclosure protects power electronics from airborne contaminants.



### UNCONDITIONAL SUPPORT AND PEACE OF MIND

With BluEdge's best-in-class lifecycle solution and customizable tiers, as well as the digital connectivity within it, customers can ensure their equipment's peak performance and longevity backed by unmatched expertise and the latest technology.



## Make your waterside economizer even better.

The AquaEdge 19MV oil-free option helps deliver the most free cooling tons to your building from an integrated waterside economizer system in three specific ways:

1. **Inverted starting** (evaporator water warmer than condenser water) enables this chiller to start even when the mechanical plant is operating with very cold condenser water
2. **Low load, low lift operation** enables the chiller to carry the portion of building load remaining when the waterside economizer can't meet the load alone
3. **Frequent starting** enables the chiller to trim during waterside economizer operation even as loads and temperatures vary so the waterside economizer can remain in operation longer

## Unconditional support and partnership – every step of the way.

Partnering with Carrier Commercial for your service and lifecycle needs brings with it the security of knowing that every facet of your investment is being carefully monitored, analyzed, and maintained. With Carrier, you are not just getting the most innovative equipment in the industry, but a trusted partner that can ensure your peace of mind over the lifetime of your equipment through Carrier's BluEdge service offering.

BluEdge is a best-in-class lifecycle solution that includes customizable plans to ensure your equipment's peak performance and longevity are backed by unmatched expertise and the latest technology for years to come. The multiple tiers within our BluEdge offering are designed to meet each customer's unique needs, and all three tiers feature cutting-edge digital features with the inclusion of Abound HVAC Performance.

With our digital connectivity platform, powered by Abound HVAC Performance, Carrier customers will receive the benefits of continuous monitoring, alarm management, and proactive insights that allow our team and your team to see issues before they arise. That means maximizing uptime, getting the most out of your equipment and optimizing your energy consumption.



## A smarter approach to unconditional control.

The AquaEdge 19MV features a Carrier SmartVu control panel, for intelligent control of all aspects of your cooling system, along with easier tracking and analysis of operational data. The intuitive touch-screen monitor can be mounted on any corner of the machine and tilts and rotates for optimum viewing. The control system can also be linked to a building automation system, enabling remote access to the chiller's running data in real time.



## Performance in any condition – and any building.

At Carrier, we have decades of knowledge and expertise across all types of buildings and applications. Our team will work with you to select and implement the right solution to meet the unique needs of your project.



Healthcare



Hospitality



Higher Education



Commercial Office



Manufacturing



Data Centers



## Benefits at a glance:

- EquiDrive two-stage back-to-back compressor – now with a magnetic bearing system option – achieves best-in-segment performance
- Compact footprint – select models fit through double doors (72" x 80") without disassembly
- Achieves <math><0.52\text{ kW/Ton}</math> (6.8 COP) and <math><0.31\text{ kW/Ton}</math> (11.3 COP) (IPLV) at AHRI conditions
- Operating range of 40°F to 95°F (4.4°C to 35°C) entering condenser water down to 10% load
- Quiet – the unit operates at less than 80 dBA\*
- Carrier SmartVu control panel allows intelligent control of all aspects of the cooling system
- Digital connectivity provides continuous monitoring and proactive chiller insights through a BluEdge service agreement

## PLV Pro™: From the creators of HAP.

Carrier's PLV Pro software provides a time-saving method to evaluate overall chiller performance based on site-specific weather data, Department of Energy (DOE) building load profiles, multi-chiller staging and economizer operation for professionals who need a quick and free-of-charge alternative to generic IPLV-based lifecycle analyses.

**PLV Pro consists of an intuitive and simple user interface that evaluates chiller system performance based on the following criteria:**

- Geographical location
- Building type
- Chiller plant capacity
- Quantity of chillers
- Chiller staging method
- Design temperatures
- Chiller plant design
- Economizer operation

PLV Pro utilizes precalculated load profiles generated with Carrier's Hourly Analysis Program (HAP) energy modeling software for accuracy and speed.

Ask your local Carrier expert about the AquaEdge 19MV and a full range of Carrier commercial HVAC system solutions:



SERVICE & RENTALS

EQUIPMENT

CONTROLS



**PLV Pro™**  
PART LOAD VALUE



carrier.com/19MV

©2023 Carrier. All Rights Reserved. Manufacturer reserves the right to discontinue, or change at any time, specifications or designs without notice or without incurring obligations. Claims noted may not be available on every model. A Carrier expert can provide guidance regarding your specific application needs. Water-cooled chillers within the scope of the AHRI WCCL certification program are certified in accordance with the AHRI Water-Cooled Water-Chilling and Heat Pump Water-Heating Packages Certification Program, which is based on AHRI Standard 550/590 (I-P) and AHRI Standard 551/591 (SI). Certified units may be found in the AHRI Directory at <http://www.ahridirectory.org>. All trademarks and service marks referred herein are property of their respective owners. Cat. No. 04-811-50069

\*Select models

